

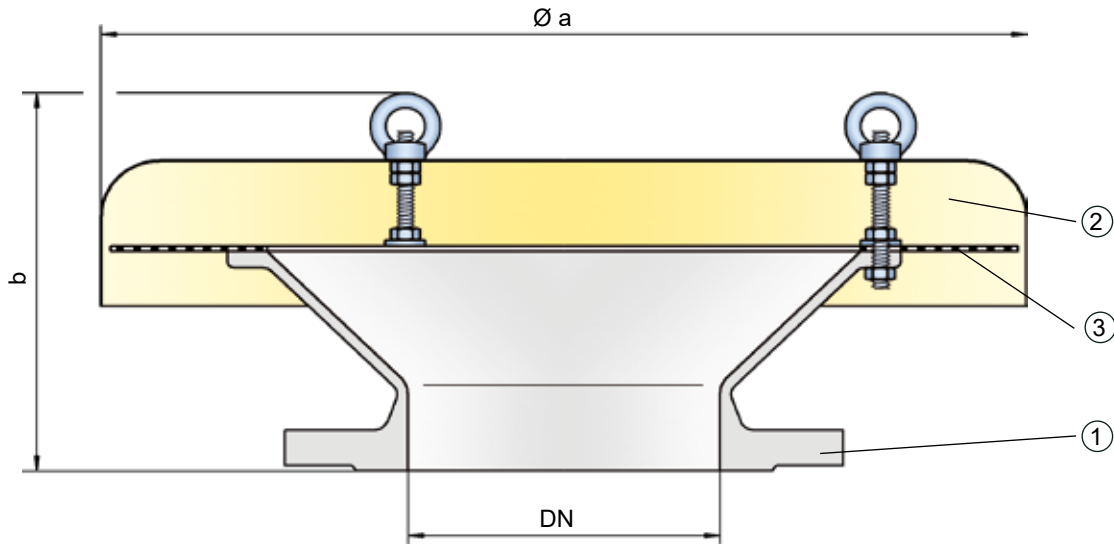

## Vent Cap, End-of-Line

### PROTEGO® EH/OS



#### Function and Description

The PROTEGO® EH/OS vent cap allows vessels which are not pressurized to vent. This device prevents rain and dirt entering the vent line. The PROTEGO® EH/OS vent cap is not flame transmission proof. It is often used in combination with detonation flame arresters, when those are used in vent lines, installed at a position which creates a long run up distance from the end of the vent line to prevent endurance burning. The PROTEGO® EH/OS will then be installed at the end of that vent line to prevent particles or rain from entering the line.

The vent cap PROTEGO® EH/OS main components are a housing (1), a weather hood (2) and a protection screen (3). The device is equipped with a fixed weather hood out of metal. The protection screen prevents particles or rain from entering the line.

#### Special Features and Advantages

- vent cap provides protection against environmental impact (harsh weather conditions, bird nests, etc.)
- cost effective device
- almost maintenance free
- certified flow performance curves

#### Design Types and Specification

Vent cap, basic design

**EH/OS**

Special designs available upon request.

**Table 1: Dimensions**

Dimensions in mm / inches

To select the nominal size (DN), please use the flow capacity chart on the following page.

DN	100 / 4"	150 / 6"	200 / 8"	250 / 10"	300 / 12"	350 / 14"	400 / 16"	500 / 20"	600 / 24"
a	295 / 11.61	550 / 21.65	550 / 21.65	600 / 23.62	600 / 23.62	600 / 23.62	650 / 25.59	800 / 31.50	1000 / 39.37
b	230 / 9.06	240 / 9.45	240 / 9.45	325 / 12.80	320 / 12.60	335 / 13.19	370 / 14.57	385 / 15.16	520 / 20.47

**Table 2: Material selection**

Design	A	B	Special materials upon request.
Housing	Steel	Stainless Steel	
Weather hood	Stainless Steel	Stainless Steel	

**Table 3: Flange connection type**

EN 1092-1; Form B1	Other types upon request.
ASME B16.5 CL 150 R.F.	

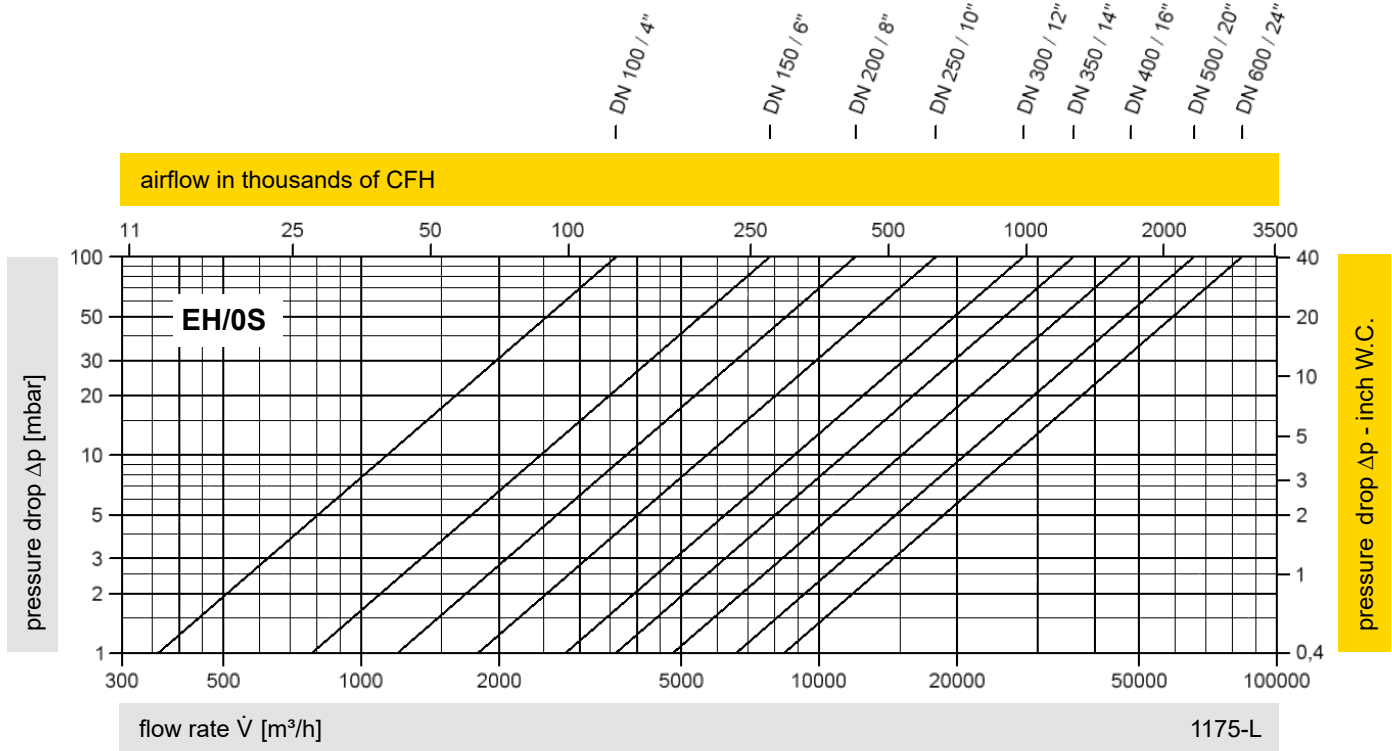

The flow capacity charts have been determined with a calibrated and TÜV certified flow capacity test rig. Volume flow  $\dot{V}$  in (m³/h) and CFH refer to the standard reference conditions of air in ISO 6358 (20°C, 1bar). For conversion to other densities and temperatures, refer to Sec. 1: "Technical Fundamentals."

