

Type test approved safety valves angle-type
for industrial applications

3.1.1

451

Safety valves made of
stainless steel, angle-type,
in combination with bursting
disc fitted upstream with
clamp connection

→ Series 451 in combination with bursting disc

■ SUITABLE FOR

Air, gases and vapours neutral and non-neutral



Steam



■ EXAMPLES OF USE

For the protection of:

- Processes, plants and vessels for neutral and non-neutral vapours and gases
- Medical technology (Sterilizers, Autoclaves)

Safety valves are set and sealed at the factory.

■ CHARACTERISTICS

- Plant operation close to design pressure combined with guaranteed high level of tightness
- Gap-free installation of the seals in contact with the medium
- CIP/ SIP capable
- Non-sticking of the safety valve seals due to the medium
- Simple installation

■ APPROVALS

TÜV-Type test approval 2107

D/G (S/G)

Requirements

AD 2000-Data sheet A1
AD 2000-Data sheet A2
VdTÜV-Data sheet 100

DGR 2014/68/EU
DIN EN ISO 4126-3
DIN EN ISO 4126-1 and 2



Pressure gauge and clamp not included in the scope of delivery.



■ MATERIAL



■ SPECIFICATION



DN 20 – DN 32

–40°C to +200°C
depending on version

2,0 – 25 bar

■ MATERIALS

Component	Material	DIN EN	ASME
Inlet body	Stainless steel	1.4404	316 L
Outlet body	Stainless steel	1.4408	CF8M
Internal parts	Stainless steel	1.4404	316 L
Spring	Stainless steel	1.4310	302
Bellows (optional)	Stainless steel	1.4571	316 Ti
Bursting disc	Stainless steel	1.4404 / 1.4435	316 L
Space monitoring device	Stainless steel	1.4404	316 L
Tri-clamp ring (TCR)	Stainless steel/PTFE	1.4404 / PTFE	316 L / PTFE

FLOW FUSION CO.,LTD.

Address : 109/13 Moo. 4, Thap ma, Mueang, Rayong 21000

Tel : +66 (0) 3868 4949 ,E-Mail : info@flow-fusion.com www.flow-fusion.com



Version 2020 / 01

www.goetze-armaturen.de | info@goetze-armaturen.de | Phone: +49 (0) 7141 / 488 94 60

Series 451 ■ VALVE VERSION

rt	Upstream fitted bursting disc and side connection for space monitoring device	gastight version of spring housing	for neutral media without counter pressure. Spring, moving parts and the environment are protected from being affected by the medium.
rtb	Upstream fitted bursting disc and side connection for space monitoring device	gastight version with bellows	for neutral and non-neutral an particularly for flammable, toxic and environmentally hazardous media and/or counter pressure up to 4 bar. Spring, moving parts and the environment are protected from being affected by the medium. Double gastight.

■ MEDIUM

G	gaseous Air, vapours, gases and - depending on safety valve version and seal - also for steam		
----------	---	--	--

■ TYPE OF LIFTING MECHANISM

0	without lifting device, standard for gastight versions		
----------	--	--	--

■ AVAILABLE NOMINAL DIAMETERS AND CONNECTION SIZES

Nominal diameter DN		20	25	32
Pipe diameter inlet		26,9	33,7	42,4
Outlet	32 (42,4)	■		
	40 (48,3)		■	
	50 (60,3)			■

■ TYPE OF CONNECTION INLET / OUTLET

KLSISO / KLSISO	Standard	Clamp connection / Clamp connection	DIN 32676-B / DIN 32676-B	Pipe standard DIN EN ISO 1127
KLSDIN / KLSDIN		Clamp connection / Clamp connection	DIN 32676-A / DIN 32676-A	Pipe standard DIN 11850 / 11866

■ SEALS

PTFE	Polytetrafluoroethylene	Flat seal	-40°C to +200°C
MD	Metal-to-metal sealing	Flat seal	-40°C to +200°C

Auxiliary seals of the bursting disc (Tri-clamp ring) made of PTFE.

■ NOMINAL DIAMETERS, CONNECTIONS, INSTALLATION DIMENSIONS

Series 451: Connection, installation dimensions, ranges of adjustment				
Nominal diameter	DN	20	25	32
Pipe diameter inlet		26,9	33,7	42,4
Connection		Clamp connection KLSISO according to DIN 32676 Series B		
Inlet	DN1	23,7	29,7	38,4
Outlet	DN2	38,4	44,3	56,3
Installation dimensions in mm	L	114	119	123,5
	L1	63,5	70	81
	h	67	72	82
	D1	50,5	50,5	64
	D2	64	64	77,5
	H	150	193	263
	do	18	23	30,3
Coefficients of flow ISO 4126-1	$\alpha_v / K_d (D/G)$	0,6	0,56	0,56
Weight	kg	2,3	3,6	6,2
Range of adjustment	bar	3,2-25	3,0-25	2,0-25

*) Valid for pressures $\geq 3,0$ bar, for lower pressure the coefficient of flow is 0,44.

■ MAIN DIMENSIONS, INSTALLATION DIMENSIONS

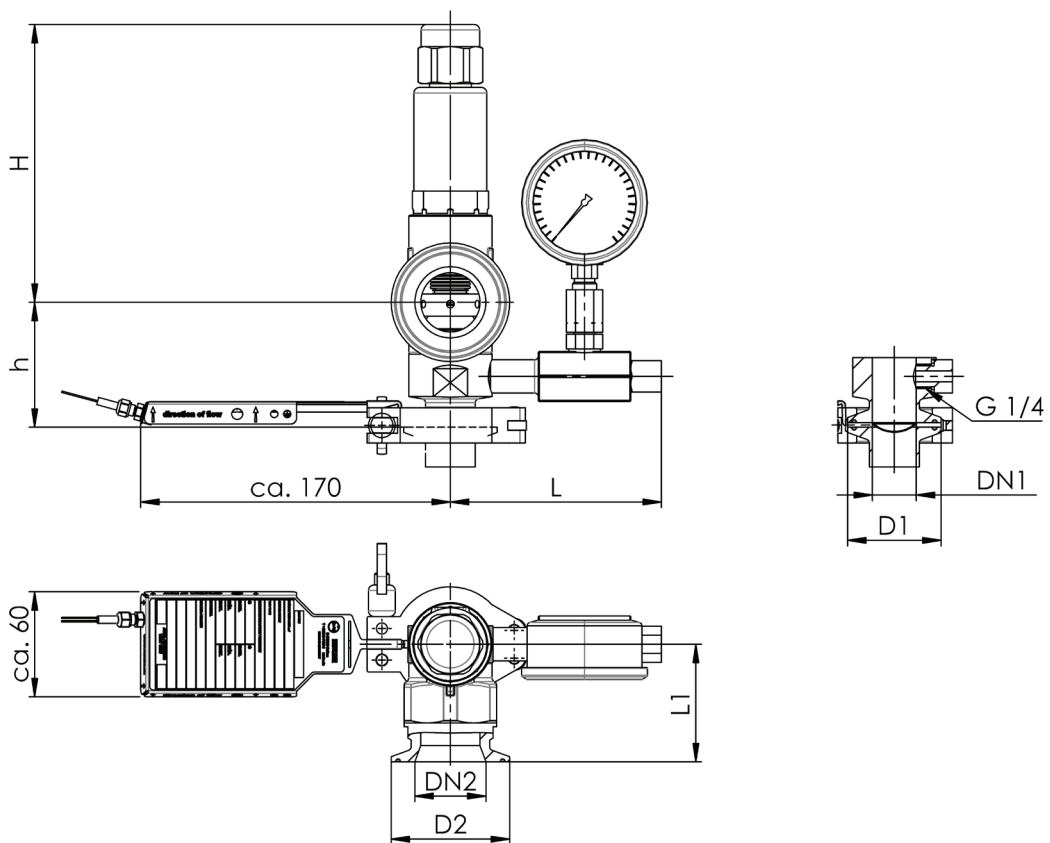

FLOW FUSION CO.,LTD.
 Address : 109/13 Moo. 4, Thap ma, Mueang, Rayong 21000
 Tel : +66 (0) 3868 4949 ,E-Mail : info@flow-Fusion.com www.flow-fusion.com

Series 451 ■ INDIVIDUAL SELECTION / VALVE CONFIGURATION

Series	Valve version	Medium	Lifting device	Nominal diameter DN	Connection type		Connection size		Seal	Options	Quantity
					Inlet	Outlet	Inlet	Outlet			
451	rtb	G	0	20	KLSISO	KLSISO	20	32	PTFE	A10	3,2
451											
451											
451											

■ TECHNICAL FINISHES, VARIANTS, ACCESSORIES

A10	Space vent valve for use with non-dangerous media	<input type="checkbox"/>	A13	Signal transmitter to indicate burst condition of bursting disc, 2-wire	<input type="checkbox"/>
A11-1	Drag pointer pressure gauge for space monitoring device, 0-10bar · (L-3085)	<input type="checkbox"/>	A14-1	Clamp with hexagonal nut for connection clamp diameter 50,5mm · (L-1586)	<input type="checkbox"/>
A11-2	Drag pointer pressure gauge for space monitoring device, 0-25bar · (L-3322)	<input type="checkbox"/>	A14-2	Clamp with hexagonal nut for connection clamp diameter 64,0mm · (L-3244)	<input type="checkbox"/>
A12-1	Pressure sensor for space monitoring device, 0-25bar · (L-3341)	<input type="checkbox"/>			<input type="checkbox"/>

■ PROPERTIES

GOX	Especially for gaseous O2 applications by employment of specific materials including oil- and grease free production process	<input type="checkbox"/>			<input type="checkbox"/>
P01	Oil- and grease-free production	<input type="checkbox"/>			<input type="checkbox"/>
P26	Indication of the process temperature in °C	<input type="checkbox"/>			<input type="checkbox"/>

■ CERTIFICATES / APPROVALS

C01	Factory certificate acc. DIN EN 10204 2.2 (WKZ 2.2)	<input type="checkbox"/>	C06	ATEX evaluation acc. to 2014/34/EU	<input type="checkbox"/>
C02	Test certificate acc. DIN EN 10204 3.1 (WPZ 3.1)	<input type="checkbox"/>	C07	SIL evaluation relating to IEC 61508-2	<input type="checkbox"/>
C03	Material test certificate acc. DIN EN 10204 3.1 (MPZ 3.1) (pressure retaining part)	<input type="checkbox"/>	C09	Seat tightness test with helium, leak detection method under vacuum incl. Factory Inspection Certificate 3.1 acc. to DIN EN 10204	<input type="checkbox"/>
C04	TÜV/DEKRA individual inspection acc. EN 10204 3.2 (TÜV/DEKRA-APZ)	<input type="checkbox"/>	C10	Certificate of oil- and grease free production	<input type="checkbox"/>
C05	Sealing material Manufacturer certification (FDA, USP 3, 3-A,...), Please indicate description of certificate:	<input type="checkbox"/>	C11	Certification of the production process especially for gaseous oxygen applications by employment of specific materials	<input type="checkbox"/>

■ ADMISSIONS / ACCREDITATIONS

AA1	EC Type examination acc. to Directive 2014/68/EU	<input checked="" type="checkbox"/>			<input type="checkbox"/>
AA2	TÜV component test acc. to VdTÜV specification sheet SV 100	<input checked="" type="checkbox"/>			<input type="checkbox"/>
		<input type="checkbox"/>			<input type="checkbox"/>

■ ENQUIRY

Copy and send to: order@goetze-armaturen.de.

Order form easily to be found online under the section for each series.

Series 451: Blowing-off rates at 10% above set pressure							
Nominal diameter DN		20		25		32	
		d0 = 18 mm		d0 = 23 mm		d0 = 30,3 mm	
Set pressure bar		I	II	I	II	I	II
Air I	2,0					833	655
	Nm ³ /h					1012	791
	3,0			682	531	1183	921
Steam II	3,2	471	366	717	558	1245	968
	kg/h						
	3,5	505	392	770	597	1336	1036
	4,0	562	435	857	663	1487	1150
	4,5	620	478	944	728	1638	1264
	5,0	677	521	1031	794	1790	1377
	5,5	734	564	1119	859	1941	1491
	6,0	791	606	1206	924	2093	1604
	6,5	849	649	1293	989	2244	1717
	7,0	906	692	1380	1054	2396	1830
	7,5	963	735	1468	1119	2547	1943
	8,0	1020	777	1555	1184	2699	2055
	8,5	1078	820	1642	1249	2850	2168
	9,0	1135	862	1729	1314	3001	2280
	9,5	1192	905	1817	1379	3153	2393
	10,0	1249	947	1904	1444	3304	2506
	11,0	1364	1033	2078	1573	3607	2731
	12,0	1478	1117	2253	1703	3910	2955
	13,0	1593	1202	2428	1832	4213	3180
	14,0	1708	1288	2602	1962	4516	3405
15,0	1822	1373	2777	2092	4819	3630	
16,0	1937	1458	2951	2221	5122	3855	
17,0	2051	1543	3126	2351	5425	4080	
18,0	2166	1628	3300	2481	5728	4306	
19,0	2280	1713	3475	2611	6030	4531	
20,0	2395	1799	3649	2741	6333	4757	
21,0	2509	1884	3824	2871	6636	4983	
22,0	2624	1970	3998	3002	6939	5209	
23,0	2738	2055	4173	3132	7242	5436	
24,0	2853	2141	4347	3263	7545	5663	
25,0	2967	2227	4522	3394	7848	5890	